



**SUSTAINABLE MACHINES,
DELICIOUS OUTCOMES**

USER MANUAL

PIZZA DOUGH SHEETER MACHINE

MODEL - DS 2

www.medatechindustries.com

MADE IN PAKISTAN

TABLE OF CONTENTS

CONTENT	Page Number
1.0. GENERAL INFORMATION	3
2.0. PRODUCT DETAILS	4
3.0. SPECIFICATIONS	5
4.0. PRODUCT CATALOG	6
5.0. FEATURES AND FUNCTIONS	7
5.1 Sheeting Capabilities	7
5.2 Economical	7
5.3 100% Stainless Steel	7
5.4 Compact Design	7
5.5 Speed Controlling	7
6.0. INSTALLATION GUIDE	8
6.1 Installation of Machine	8
7.0. OPERATION MANUAL	9
7.1 Main Switch	9
7.2 Safety Bar	9
5.0. SAFETY GUIDELINE AND PRECAUTIONS	10
6.0. TROUBLESHOOTING SECTION	11
ABOUT US	12
CONTACT US	12

1.0 GENERAL INFORMATION

PIZZA DOUGH SHEETER MACHINE

Model: MODEL - DS 2

DESCRIPTION: Machinery used for Sheeting Pizza Dough balls and making round sheets for making samosa. A fully Automatic single-phase stainless-steel machine. All the motors included in this machine are of high quality and are durable as well as reliable with long life. This machine is shipped worldwide. The main objective of this machine is to process and make round sheets by processing pizza dough balls, and and make them into perfectly oval or round sheets without the use of hand for later processing. You just put the dough ball into the hopper and the machine takes care of the rest.



DS 2 - Pizza Dough Sheeter Machine

2.0 PRODUCT DETAILS

Model: DS 2	Gross Weight: 135 kg
Motors: AC Motors	A: 27 inches
Power Input: 220 Volts / 440 Volts	B: 13 inches
HS- Code: 8438.1000	C: 14 inches
Net Weight: 120 kg	D: 24 inches
Packing For Shipping: 20 x 28 x 32 inches , 15 kg	E: 16 inches

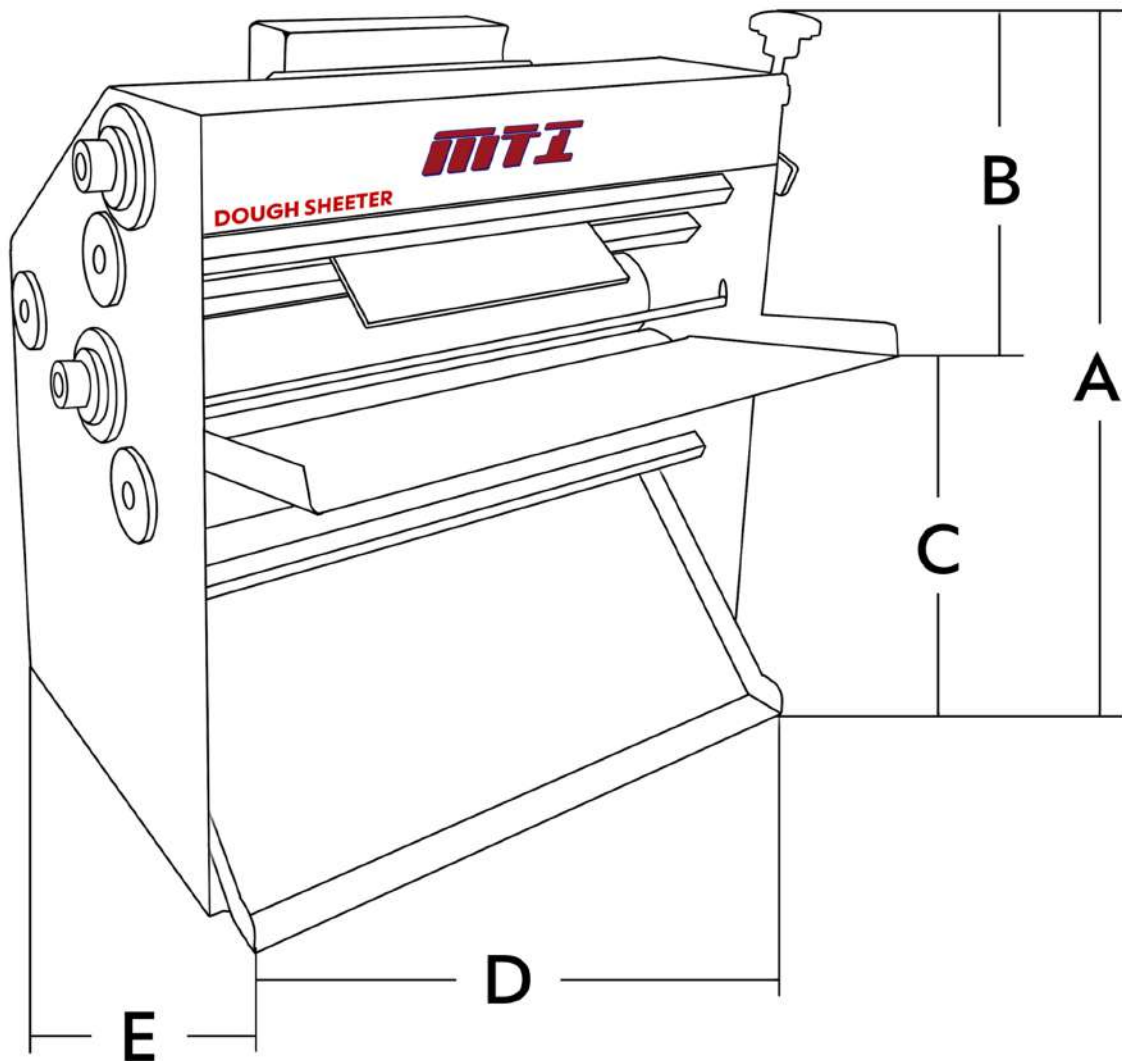

MEASUREMENTS - FRONT VIEW

3.0 SPECIFICATIONS

- ❖ High Tech Machine designed for SHEETING PIZZA DOUGH
- ❖ Dedicated programme for making your preferred size of Dough Sheet
- ❖ You can control and get your desirable thickness of the sheet through Special Thickness Control System
- ❖ Both Three Phase 440 Volt AC Input and 220 Volt AC Input Compatible
- ❖ Extraordinary design reduces the footprint of the machine and improves comfort
- ❖ Large capacity hopper for containing bulk material all at once for processing
- ❖ Easy access to hopper for cleaning.
- ❖ Extremely easy to clean thanks to the perfect flatness of the support product plan made on AISI 304 stainless steel
- ❖ Practical and intuitive control panel for controlling all the functionalities of the machine
- ❖ Optional adjustable speed of the machine
- ❖ Fuse and emergency switch given for safety
- ❖ 1-year warranty of all components

4.0 PRODUCT CATALOG

Following is the product catalog labelled for clarification;



SIDE VIEW



FRONT VIEW



TOP VIEW



REAR VIEW



SIDE VIEW



SIDE VIEW



COLLECTING TRAY



HOPPER



TOP VIEW

5.0 FEATURES AND FUNCTIONS

5.1 SHEETING CAPABILITIES:

Pizza Dough Sheeter Machine is a model with diverse and very useful capabilities. One of its main features is its Dough Sheeting capabilities. It can make sheets all kinds and sizes of dough balls of samosa and process them into perfectly round and oval sheets of dough for further processing. This diverse range makes this machine unique and trustworthy and adds more value to this product. All you are required to do is to put your dough ball into the hopper of the machine and the machine will take care of the rest and provide you with oval or round pizza sheets of Dough you require.

5.2 ECONOMICAL:

This Machine is a highly economical machine, meaning that it requires very less amount of electricity to run on compared to other machinery in your food factory.

5.3 100% STAINLESS:

The product plan is made on AISI 304 stainless steel thick and it is made with a one hundred percent stainless steel body and fittings for it to be reliable and durable. This makes the machine full stainless thoroughly and throughout its lifetime it does not rust and remains durable, reliable and extremely easy to clean.

5.4 COMPACT DESIGN:

This model is made with a design that is highly compact and smart so it can fit easily in your food factory and this design is user friendly and easy to carry around in case the machine needs to be moved.

5.5 SPEED CONTROLLING:

There is an optional speed control system for the customers that want more control over the machine. It is controlled by the help four speed control dimmers. This feature gives all the controls of the machine in the hand of the user. With the help of this feature, you can control what size of the product you the machine to round and what amount of pieces per minute you desire from the machine. All of these are in your control through the speed control option.

6.0 INSTALLATION GUIDE

6.1 INSTALLATION OF MACHINE

This machine does not require any specific installation because all parts come combined with the machine and fixed. All you have to do is place the machine on a desktop and plug it in electricity and start the work.



DESKTOP SETUP

7.0 OPERATION MANUAL

7.1 Main Switch

This is the only switch present in the control panel and it operates the mixer. Put the dough ball in the hopper and turn the switch on. It is responsible for the switching on the machine.

7.2 Safety Bar

There is a safety bar in the machine where the Dough Sheeter Rollers are spinning for the safety of the machine operator. It provides safety when the operator flips the dough sheet and puts in again in the machine into the roller. It stops and limits the hand of the operator to surpass certain limit which is away for the rollers and protects the hand of the operator.

8.0 SAFETY GUIDELINES AND PRECAUTIONS

Guidelines and precautions for running this machine safely are mentioned below, following them would be necessary if you want a to work safely and effectively with this machine:

- ❖ Do not change the cutter if the machine is running.
- ❖ Do not change the bush of the hopper if the machine is running.
- ❖ For Extra safety, the machine has a built-in fuse that goes off in the case of a short circuit or any electrical emergency.
- ❖ The machine has an emergency switch that can be used in the case of hazard.
- ❖ Do not remove the worm from the hopper if the machine is running.
- ❖ Make sure to check if the machine is plugged out before cleaning the machine so you are safe from any kind of electrical damage.
- ❖ Do not put your hand to check the Hopper's exit/entry if the machine is running.
- ❖ You should only touch and control the dimmers that are present at the side of the machine to control the machine and nothing else when the machine is in running state.

9.0 TROUBLESHOOTING SECTION/TECHNICAL INSTRUCTIONS

Instructions about troubleshooting and technical instructions about this machine are given below:

- In case of power overload or power failure from backend, the machine may stop working, that is because of the safety code of the machine to prevent any kind of electrical hazard. To fix this, please change the fuse that is located on the back of the dimmer panel, on the rear end of the machine.
- If the conveyor is not centred on the conveyor plate, you are required to adjust the nuts that are located on the either side of the conveyor belt on a bolt with the help of a wrench or key.
- If the machine isn't cutting properly, please adjust the cutter's position from the bolt located at the bottom of the cutter holder, as so that the cutting wire touches the Teflon bush with a slight kiss when it passes it to get the best results.

ABOUT US

Our Company

We are based in Faisalabad which is one of biggest industrial cities in Pakistan. Our focus is particularly on the advancement of food machinery related to sweets and bakery department. Our company is responsible for major advancements in the industry of sweets here in Pakistan and internationally. Our products are delivered nationwide in Pakistan and shipped internationally to United Kingdom, Saudi Arabia and many more countries.

Here at Medatech Industries, we work hard to provide you the best quality machines and equipment at a reasonable and affordable price. The designs we use in our machines are unique and compact to keep our machines portable and handy. The appliances used in the production are globally sourced from Japan and USA for high quality and durability.

CONTACT US

You can contact us at the details given below for further information about our line of products and/or to place order. We are shipping worldwide.

Our Location

P-6297, street 6, Muhammad Khan Town, West Canal Road, Faisalabad, 38000
Punjab, Pakistan

Call Us

+92 3007650714
+92 3018650700
+92 3008650700
+92 3007650700

Email Us

admin@medatechindustries.com

Checkout our website

www.medatechindustries.com