



RASGULLA & GULAAB JAMAN MAKING MACHINE

Sweet Ball Making Machine
PRO Model - RG Pro



- High Tech Machine designed for Rounding Dough Balls of Rasgulla and Gulaab Jaman
- This is Pro Model of the the machine and provides higher piece per second rounding resulting in higher production speed
- Extraordinary design reduces the footprint of the machine and improves comfort
- Large capacity hopper for containing bulk material all at once for processing
- Easily removable hopper for cleaning.
- Extremely easy to clean thanks to the perfect flatness of the support product plan made on AISI 304 stainless steel 2 mm thick
- Automatic cleaning of the conveyor through scrapers
- Adjustable and Variable sized hopper outlets for catering a large number of sizes of sweet balls
- Practical and intuitive control panel for speed controlling all the functionalities of the machine
- Adjustable conveyor
- Dedicated programme for rounding of sweet balls precisely
- Dedicated programme for cutting sweet balls of all sizes
- Adjustable conveyor height for precise rounding
- Additional Flattener given on conveyor to flatter sweet balls to make Gulaab Jaman
- Rotating collection dishes at the end for easy collection of the product
- Fuse and emergency switch given for safety
- 1-year warranty of all components



DOUGH ROUNDER

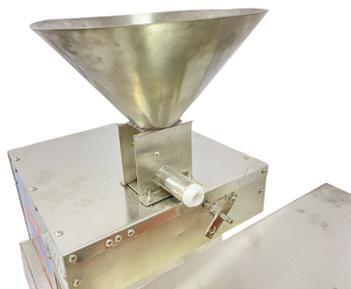

HOPPER AND KNIFE



CUTTER



COLLECTING DISH

PRODUCT CATALOG

Following is the product catalog labelled for clarification;



SIDE VIEW



SIDE VIEW



MEDATECH INDUSTRIES



COLLECTING DISH

MEDATECH INDUSTRIES



MEDATECH INDUSTRIES

SIDE VIEW



MEDATECH INDUSTRIES

HOPPER

TOP VIEW

HOPPER



MEDATECH INDUSTRIES

DOUGH CUTTER

DOUGH CUTTER



MEDATECH INDUSTRIES

BACK SIDE VIEW



Control Panel

DOUGH ROUNDER

MEDATECH INDUSTRIES

DOUGH ROUNDER



DIMMER 1: (CONVEYOR)

This dimmer is responsible for the regulation of the speed of the conveyor. This dimmer should be set to 100% speed.

DIMMER 2: (WORM)

This dimmer is responsible for the regulation of the speed of the worm. This dimmer is set according to your size needs. By increasing its speed, the size of the product also increases and vice versa.

DIMMER 3: (ROUNDER)

This Dimmer is responsible for the regulation of the speed of the dough rounder. It should be set at a speed where it rounds your required size of dough piece precisely. By increasing and decreasing its speed you can calibrate it to your required size.

DIMMER 4: (CUTTER)

This Dimmer is responsible for the regulation of the speed of the cutter. It should be set at a speed where it cuts at least one piece per second. By increasing its speed, the size of the product also decreases and vice versa.

DIMMER 5: (DISH)

This Dimmer is responsible for the regulation of the speed of Collection Dish that collects the Gulaab Jaman and Rasgulla.



CONTROL PANNEL



HOPPER

INSTALLATION OF HOPPER

Fix the hopper on top of the machine where four bolts are placed and fix the butterfly nuts onto the bolts for fixing of the hopper

INSTALLATION OF WORM

Insert the worm in Hopper and rotate it clockwise to lock it.

INSTALLATION OF BUSH

Insert the compatible bush of your requirement from the accessory box into the hopper's pipe and rotate the Bush Clockwise to tighten it and lock it.

ROUNDING CAPABILITIES

Sweet Ball Making Machine is a model with diverse and very useful capabilities. One of its main features is its Rounding capabilities. It can round all kinds of Rasgulla and Gulaab Jaman Dough with ease and excellence. This diverse range makes this machine unique and trustworthy and adds more value to this product. All you are required to do is to put your mixture, into the hopper of the machine and the machine will take care of the rest and provide you with well-rounded and Divided Balls of Dough you require.



DOUGH ROUNDER



COLLECTION DISH

INSTALLATION OF COLLECTING DISH

Place the collecting dish stand in the motor shaft that is present in front of the conveyor and fixed on the machine's stand. Rotate and screw the collecting dish stand until its tightly fixed on the stand. Now place the collecting dish on the stand and you're good to go.

Product Details

Model: RG Pro

Motors: AC and DC Motors

Power Input: 220 Volts

HS- Code: 8438.2000

Net Weight: 120 kg

Packing For Shipping: 62 x 26 x 28 inches , 25 kg

Gross Weight: 145 kg

A: 33 inches

B: 48 inches

C: 34 inches

D: 90 inches

E: 82 inches

F: 18 inches

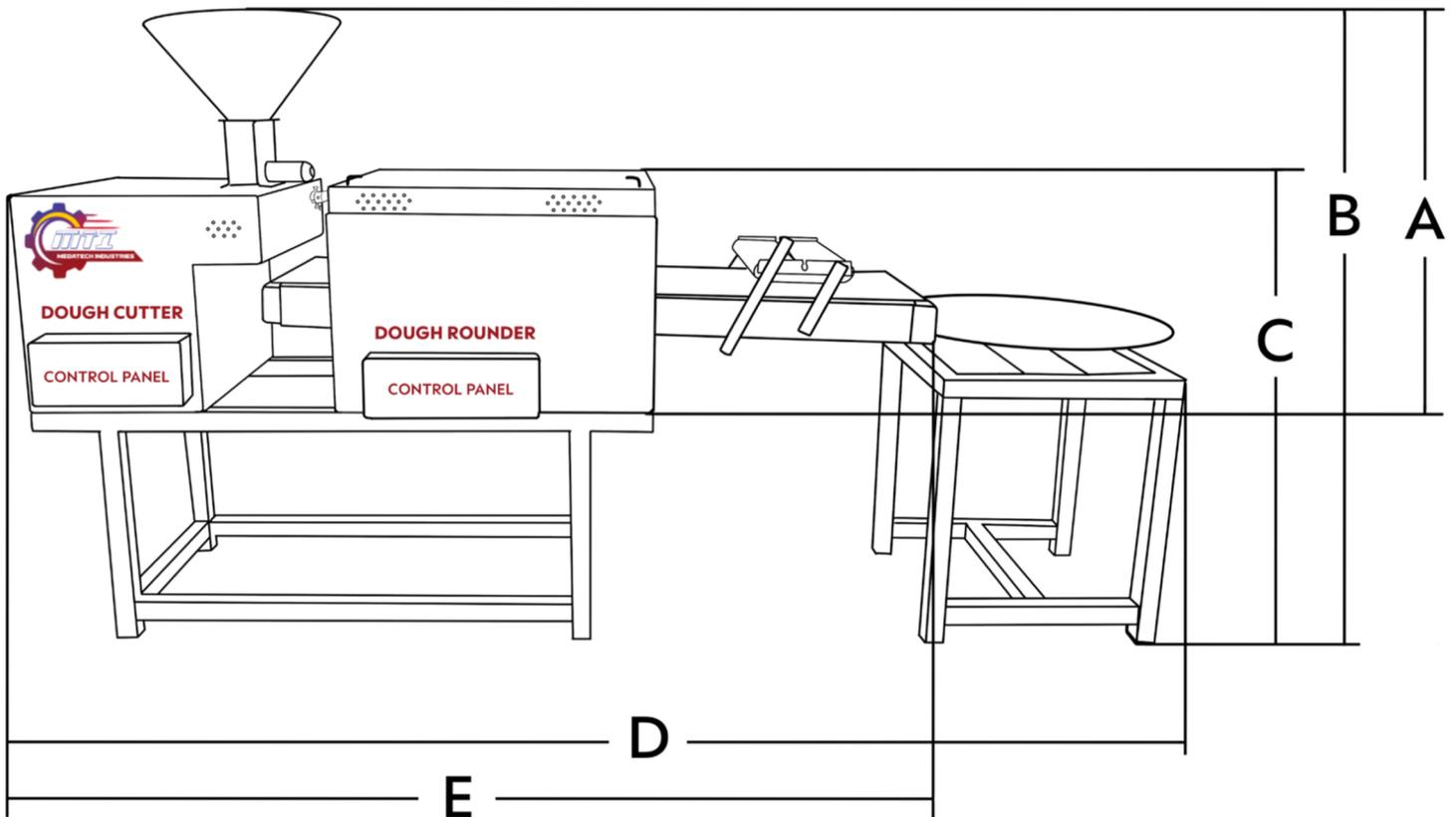
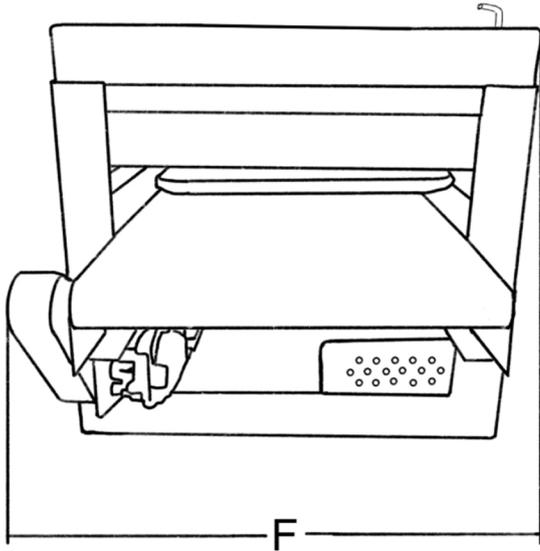

MEASUREMENTS - SIDE VIEW

MEASUREMENTS - REAR VIEW



For more information

www.medatechindustries.com

admin@medatechindustries.com

Contact Us

+92 301 865 0700

+92 300 765 0714