



PIZZA DOUGH SHEETER MACHINE

Model - DS 2



DS 2
PIZZA DOUGH
SHEETER MACHINE

- High Tech Machine designed for SHEETING PIZZA DOUGH
- Dedicated programme for making your preferred size of Dough Sheet
- You can control and get your desirable thickness of the sheet through Special Thickness Control System
- Both Three Phase 440 Volt AC Input and 220 Volt AC Input Compatible
- Extraordinary design reduces the foot-print of the machine and improves comfort
- Large capacity hopper for containing bulk material all at once for processing
- Easy access to hopper for cleaning.
- Extremely easy to clean thanks to the perfect flatness of the support product plan made on AISI 304 stainless steel
- Practical and intuitive control panel for controlling all the functionalities of the machine
- Optional adjustable speed of the machine
- Fuse and emergency switch given for safety
- 1-year warranty of all components



HOPPER



SHEETER

PRODUCT CATALOG

Following is the product catalog labelled for clarification;



SIDE VIEW



FRONT VIEW



TOP VIEW



REAR VIEW



SIDE VIEW



SIDE VIEW



COLLECTING TRAY



HOPPER

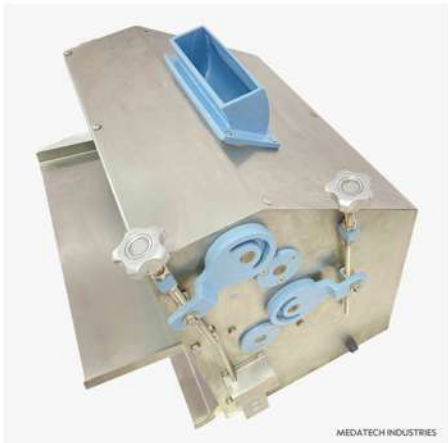

TOP VIEW



INSTALLATION GUIDE

INSTALLATION OF MACHINE

This machine does not require any specific installation because all parts come combined with the machine and fixed. All you have to do is place the machine on a desktop and plug it in electricity and start the work.



DESKTOP SETUP

OPERATION MANUAL

Main Switch

This is the only switch present in the control panel and it operates the mixer. Put the dough ball in the hopper and turn the switch on. It is responsible for the switching on the machine.

Safety Bar

There is a safety bar in the machine where the Dough Sheeter Rollers are spinning for the safety of the machine operator. It provides safety when the operator flips the dough sheet and puts in again in the machine into the roller. It stops and limits the hand of the operator to surpass certain limit which is away for the rollers and protects the hand of the operator.

Product Details

Model: DS 2	Gross Weight: 135 kg
Motors: AC Motors	A: 27 inches
Power Input: 220 Volts / 440 Volts	B: 13 inches
HS- Code: 8438.1000	C: 14 inches
Net Weight: 120 kg	D: 24 inches
Packing For Shipping: 20 x 28 x 32 inches , 15 kg	E: 16 inches

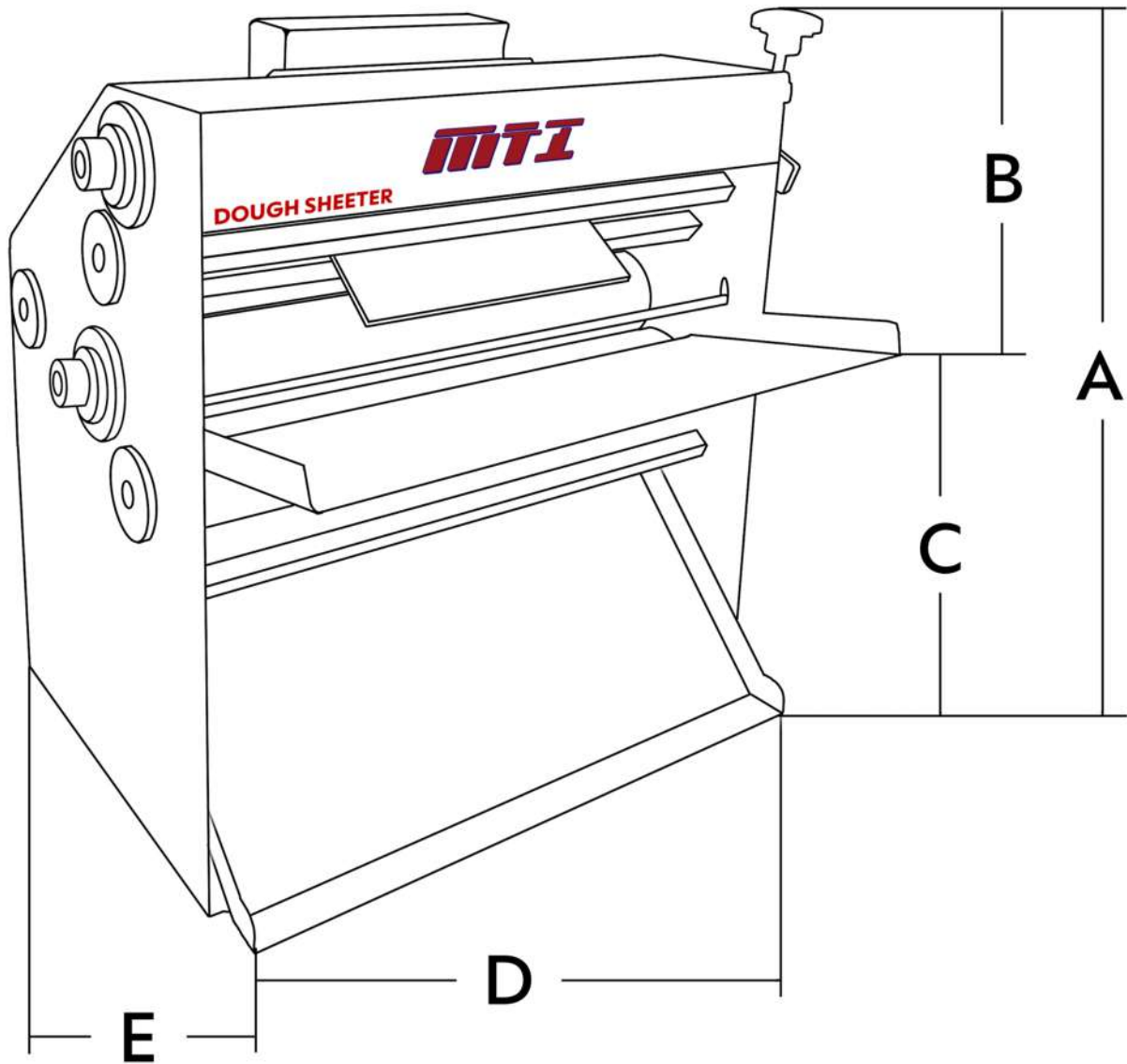

MEASUREMENTS - FRONT VIEW

For more information

www.medatechindustries.com

admin@medatechindustries.com

Contact Us

+92 301 865 0700

+92 300 765 0714