



# ALMOND SLICER MACHINE

## Base Model - NS 1



NS 1  
ALMOND SLICER MACHINE

- High Tech Machine designed for Slicing Almonds in thin layers
- Very fast speed, can slice large amounts of almond in a single push
- Extraordinary design reduces the footprint of the machine and improves comfort
- Large capacity hopper for containing bulk material all at once for processing
- Easily removable hopper for cleaning.
- Extremely easy to clean thanks to the perfect flatness of the support product plan made on AISI 304 stainless steel
- Adjustable and Variable thickness of almonds that can be controlled by the knob in the middle of the hoppers
- Three different hoppers for different kinds of slicing according to your need
- Dedicated programme for slicing the almonds extremely well and with accuracy
- Adjustable thickness of almonds according to your need
- Fuse and emergency switch given for safety
- 1-year warranty of all components



THICKNESS CONTROL KNOB

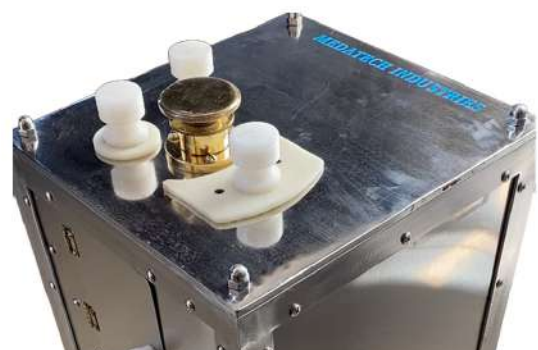

THREE DIFFERENT HOPPERS

# PRODUCT CATALOG

Following is the product catalog labelled for clarification;



RIGHT SIDE VIEW



LEFT CORNER



LEFT SIDE



COLLECTOR



LEFT SIDE



FRONT



## **ALMOND SLICE THICKNESS**

Thickness of the Almond slice is controlled by the golden knob present in the centre of the hopper. Just rotate the knob clockwise to decrease the thickness of the almond slice and rotate the knob counter clockwise to increase the thickness of the almond slice.



## **INSTALLATION GUIDE**

### **INSTALLATION OF MACHINE**

This machine does not require any specific installation because all parts come combined with the machine and fixed. All you have to do is place the machine on a desktop and plug it in electricity and start the work.

## **OPERATION MANUAL**

### **Main Switch**

This is the only switch present in the control panel and it operates the mixer. Put the dough ball in the hopper and turn the switch on. It is responsible for the switching on the machine.

# Product Details

**Model:** NS 1

**Gross Weight:** 50 kg

**Motors:** AC Motors

**A:** 13 inches

**Power Input:** 220 Volts

**B:** 13 inches

**HS- Code:** 8438.3090

**C:** 13 inches

**Net Weight:** 40 kg

**D:** 13 inches

**Packing For Shipping:** 15 x 15 x 15 inches , 10 kg

**E:** 13 inches

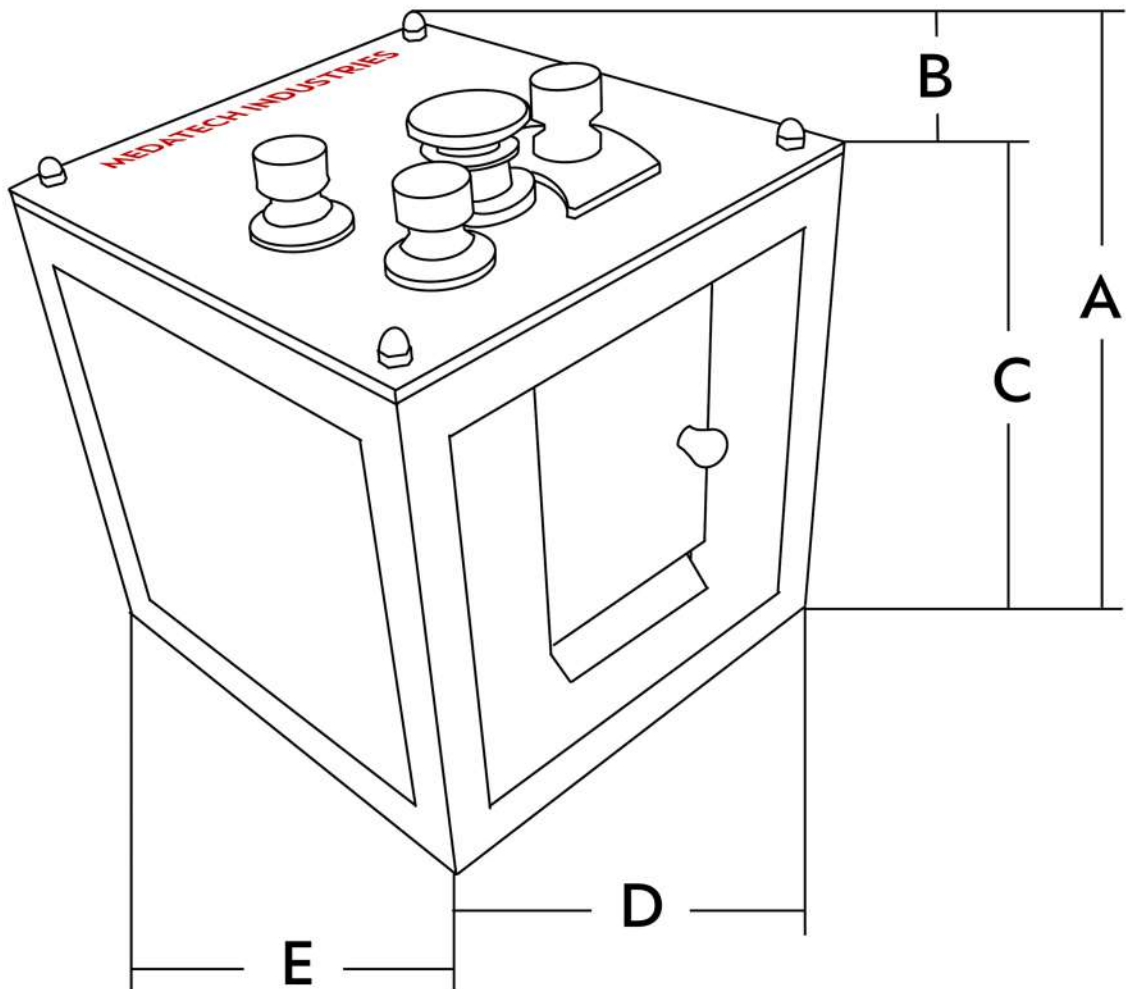

MEASUREMENTS - FRONT VIEW

For more information

[www.medatechindustries.com](http://www.medatechindustries.com)

[admin@medatechindustries.com](mailto:admin@medatechindustries.com)

Contact Us

+92 301 865 0700

+92 300 765 0714